

## 8293 GPIB TRANSCEIVER

- Nine Open-collector or Three-state Line Drivers
- 48 mA Sink Current Capability on Each Line Driver
- Nine Schmitt-type Line Receivers
- High Capacitance Load Drive Capability
- Single 5V Power Supply
- 28-Pin Package
- Low Power HMOS Design
- On-chip Decoder for Mode Configuration
- Power Up/Power Down Protection to Prevent Disrupting the IEEE Bus
- Connects with the 8291 and 8292 to Form an IEEE Standard 488 Interface Talker/Listener/Controller with no Additional Components
- Only Two 8293's Required per GPIB Interface
- On-Chip IEEE-488 Bus Terminations

The Intel® 8293 GPIB Transceiver is a high current, non-inverting buffer chip designed to interface the 8291 GPIB Talker/Listener or the 8292 GPIB Controller with the 8291 to the IEEE Standard 488-1978 Instrumentation Interface Bus. Each GPIB interface would contain two 8293 Bus Transceivers. In addition, the 8293 can also be used as a general purpose bus driver.

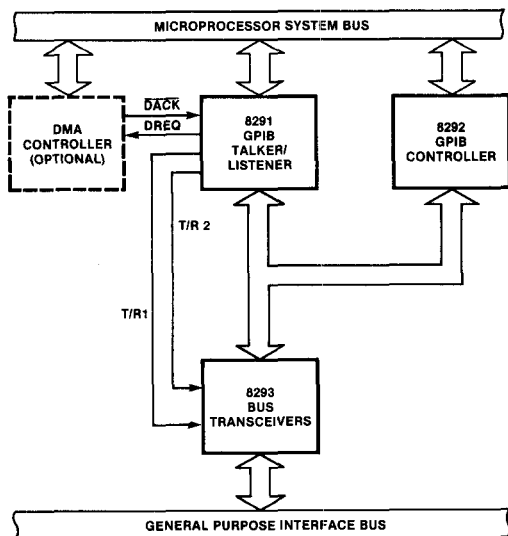

Figure 1. 8291, 8292, 8293 Block Diagram

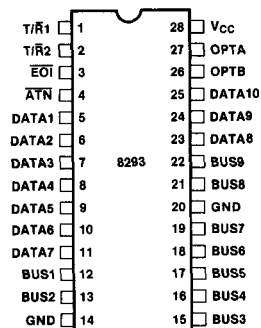

Figure 2. Pin Configuration

Table 1. Pin Description

Symbol	Pin No.	Type	Name and Function
BUS1-BUS9	12, 13, 15-19, 21, 22	I/O	<b>GPIB Lines, GPIB Side:</b> These are the IEEE-488 bus interface driver/receivers. Using the mode select pins, they can be configured differently to allow direct connections between the 8291 GPIB Talker/Listener and the 8292 GPIB Controller.
DATA1-DATA10	5-11, 23-25	I/O	<b>GPIB Lines 8291/92 Side:</b> These are the pins to be connected to the 8291 and 8292 to interface with the GPIB bus. Their use is programmed by the two mode select pins, OPTA and OPTB. All these pins are TTL compatible.
T/R1	1	I	<b>Transmit Receive 1:</b> This pin controls the direction for NDAC, NRFD, DAV, and DIO1-DIO8. Input is TTL compatible.
T/R2	2	I	<b>Transmit Receive 2:</b> This pin controls the direction for EO1. Input is TTL compatible.

Symbol	Pin No.	Type	Name and Function
EO1	3	I/O	<b>End Or Identify:</b> This pin indicates the end of a multiple byte transfer or, in conjunction with ATN, addresses the device during a polling sequence. It connects to the 8291 and is switched between transmit and receive by T/R2. This pin is TTL compatible.
ATN	4	O	<b>Attention:</b> This pin is used by the 8291 to monitor the GPIB ATN control line. It specifies how data on the DIO lines is to be interpreted. This output is TTL compatible.
OPTA OPTB	27 26	I I	<b>Mode Select:</b> These two pins are to control the function of the 8293. A truth table of how this programs the various modes is in Table 2.
VCC	28	P.S.	<b>Voltage:</b> Positive power supply (5V ± 10%).
GND	14, 20	P.S.	<b>Ground:</b> Circuit ground potential.

Table 2. 8293 Mode Selection Pin Mapping

Pin Name	Pin No.	IEEE Implementation Name			
		Mode 0	Mode 1	Mode 2	Mode 3
OPTA	27	0	1	0	1
OPTB	26	0	0	1	1
DATA1	5	IFC	DIO8	IFC	DIO8
BUS1	12	IFC*	DIO8*	IFC*	DIO8*
DATA2	6	REN	DIO7	REN	DIO7
BUS2	13	REN*	DIO7*	REN*	DIO7*
DATA3	7	NC	DIO6	EOI2	DIO6
BUS3	15	EOI*	DIO6*	EOI*	DIO6*
DATA4	8	SRQ	DIO5	SRQ	DIO5
BUS4	16	SRQ*	DIO5*	SRQ*	DIO5*
DATA5	9	NRFD	DIO4	NRFD	DIO4
BUS5	17	NRFD*	DIO4*	NRFD*	DIO4*
DATA6	10	NDAC	DIO3	NDAC	DIO3
BUS6	18	NDAC*	DIO3*	NDAC*	DIO3*
DATA7	11	T/RIO1	NC	ATNI	ATNO
DATA8	23	T/RIO2	DIO2	ATNO	DIO2
BUS7	19	ATN*	DIO2*	ATN*	DIO2*
DATA9	24	GIO1	DAV	CIC	DAV
BUS8	21	GIO1*	DAV*	CLTH	DAV*
DATA10	25	GIO2	DIO1	IFCL	DIO1
BUS9	22	GIO2*	DIO1*	SYC	DIO1*
T/R1	1	T/R1	T/R1	T/R1	T/R1
T/R2	2	T/R2	NC	T/R2	IFCL
EO1	3	EO1	EO1	EO1	EO1
ATN	4	ATN	ATN	ATN	ATN

\*Note: These pins are the IEEE-488 bus non-inverting driver/receivers. They include all the bus terminations required by the Standard and may be connected directly to the GPIB bus connector.

**GENERAL DESCRIPTION**

The 8293 is a bidirectional transceiver. It was designed to interface the Intel 8291 GPIB Talker/Listener and the Intel® 8292 GPIB Controller to the IEEE Standard 488-1978. Instrumentation Bus (also referred to as the GPIB Bus). The Intel GPIB Bus Transceiver meets or exceeds all of the electrical specifications defined in the IEEE Standard 488-1978, Section 3.3-3.5, including the required bus termination specifications.

The 8293 can be hardware programmed to one of four modes of operation. These modes allow the 8293 to be configured to support both a Talker/Listener/Controller environment and Talker/Listener environment. In addition, the 8293 can be used as a general purpose three-state (push-pull) or open-collector bus transceiver with nine receiver/drivers. Two modes are used to support a Talker/Listener environment (see Figure 3), and to support a Talker/Listener/Controller environment (see Figure 4). Mode 1 is the general purpose mode.

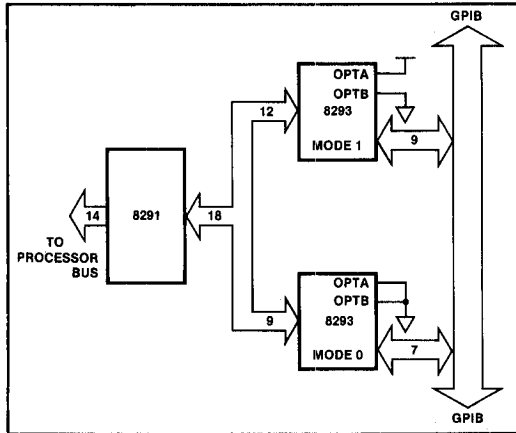

**Figure 3. Talker/Listener Configuration**

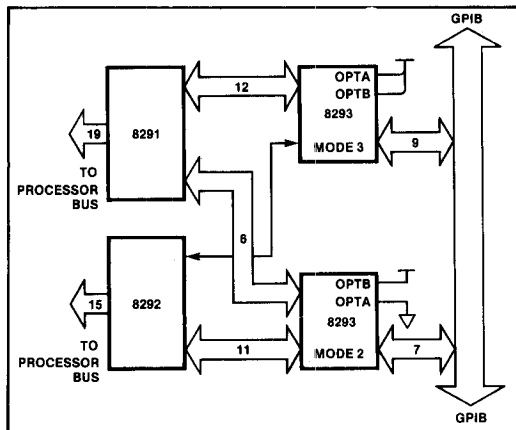

**Figure 4. Talker/Listener/Controller Configuration**

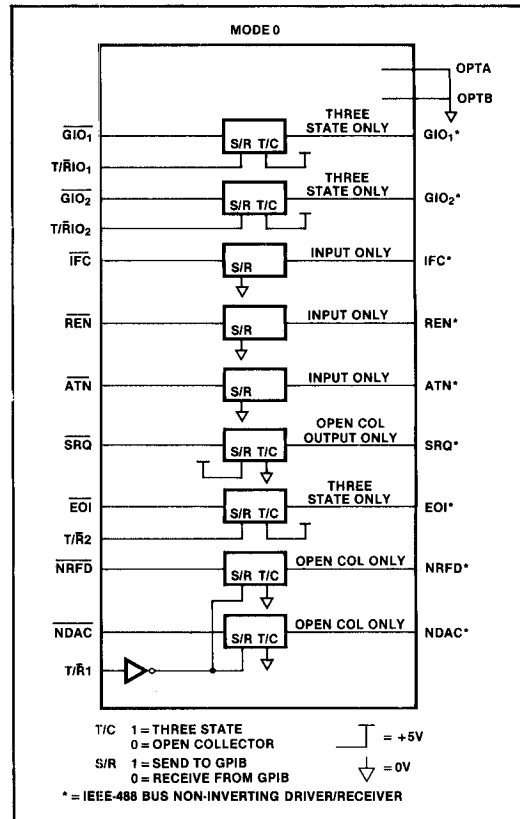

**Figure 5. Talker/Listener Control Configuration**

**Table 3. Mode 0 Pin Description**

Symbol	Pin No.	Type	Name and Function
T/R1	1	I	<b>Transmit Receive 1</b> Direction control for NDAC and NRFD. If T/R1 is high, then NDAC* and NRFD* are receiving. Input is TTL compatible.
NDAC	10	I/O	<b>Not Data Accepted:</b> Processor GPIB bus handshake control line; used to indicate the condition of acceptance of data by device(s). It is TTL compatible.
NDAC*	18	I/O	<b>Not Data Accepted:</b> IEEE GPIB bus handshake control line. When an input, it is a TTL compatible Schmitt-trigger. When an output, it is an open-collector driver with 48 mA sinking capability.
NRFD	9	I/O	<b>Not Ready For Data:</b> Processor GPIB bus handshake control line; used to indicate the condition of readiness of device(s) to accept data. This pin is TTL compatible.

Table 3. Mode 0 Pin Description (Continued)

Symbol	Pin No.	Type	Name and Function
NRFD*	17	I/O	<b>Not Ready For Data:</b> IEEE GPIB bus handshake control line. When an input, it is a TTL compatible Schmitt-trigger. When an output, it is an open-collector driver with a 48 mA current sinking capability.
T/R2	2	I	<b>Transmit Receive 2:</b> Direction control for EOI. If T/R2 is high, EOI* is sending. Input is TTL compatible.
EOI	3	I/O	<b>End Or Identify:</b> Processor GPIB bus control line; is used by a talker to indicate the end of a multiple byte transfer. This pin is TTL compatible.
EOI*	15	I/O	<b>End Or Identify:</b> IEEE GPIB bus control line; is used by a talker to indicate the end of a multiple byte transfer. This pin is a three-state (push-pull) driver capable of sinking 48 mA and a TTL compatible receiver with hysteresis.
SRQ	8	I	<b>Service Request:</b> Processor GPIB bus control line; used by a device to indicate the need for service and to request an interruption of the current sequence of events on the GPIB. It is a TTL compatible input.
SRQ*	16	O	<b>Service Request:</b> IEEE GPIB bus control line; it is an open collector driver capable of sinking 48 mA.
REN	6	O	<b>Remote Enable:</b> Processor GPIB bus control line; used by a controller (in conjunction with other messages) to select between two alternate sources of device programming data (remote or local control). This output is TTL compatible.
REN*	13	I	<b>Remote Enable:</b> IEEE GPIB bus control line. This input is a TTL compatible Schmitt-trigger.
ATN	4	O	<b>Attention:</b> Processor GPIB bus control line; used by the 8291 to determine how data on the DIO signal lines are to be interpreted. This is a TTL compatible output.
ATN*	19	I	<b>Attention:</b> IEEE GPIB bus control line; this input is a TTL compatible Schmitt-trigger.
IFC	5	O	<b>Interface Clear:</b> Processor GPIB bus control line; used by a controller to place the interface system into a known quiescent state. It is a TTL compatible output.

Symbol	Pin No.	Type	Name and Function
IFC*	12	I	<b>Interface Clear:</b> IEEE GPIB bus control line. This input is a TTL compatible Schmitt-trigger.
T/RIO1 T/RIO2	11 23	I I	<b>Transmit Receive General IO:</b> Direction control for the two spare transceivers. These pins are TTL compatible.
GIO1 GIO2	24 25	I/O I/O	<b>General IO:</b> This is the TTL side of the two spare transceivers. These pins are TTL compatible.
GIO* GIO2*	21 22	I/O I/O	<b>General IO:</b> These are spare three-state (push-pull) drivers/Schmitt-trigger receivers. The drivers can sink 48 mA.

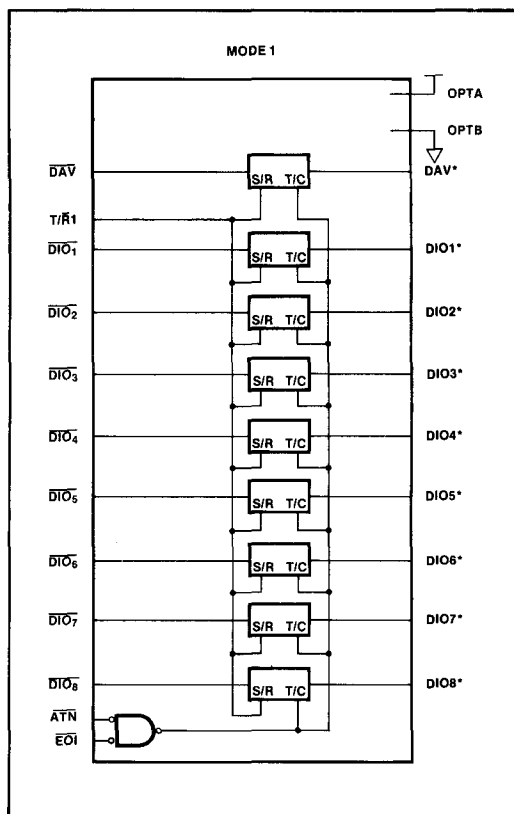

Figure 6. Talker/Listener Data Configuration

Table 4. Mode 1 Pin Description

Symbol	Pin No.	Type	Name and Function
T/R1	1	I	<b>Transmit Receive 1:</b> Controls the direction for DAV and the DIO lines. If T/R1 is high, then all these lines are sending information to the IEEE GPIB lines. This input is TTL compatible.
EOI ATN	3 4	I I	<b>End Of Sequence And Attention:</b> Processor GPIB control lines. These two control signals are ANDed together to determine whether all the transceivers in the 8293 are three-state (push-pull) or open-collector. When both signals are low (true), then the controller is performing a parallel poll and the transceivers are all open-collector. These inputs are TTL compatible.
DAV	24	I/O	<b>Data Valid:</b> Processor GPIB bus handshake control line; used to indicate the condition (availability and validity) of information on the DIO signals. It is TTL compatible.
DAV*	21	I/O	<b>Data Valid:</b> IEEE GPIB bus handshake control line. When an input, it is a TTL compatible Schmitt-trigger. When DAV* is an output, it can sink 48 mA.
DIO1- DIO8	25, 23, 10, 9, 8, 7, 6, 5	I/O	<b>Data Input/Output:</b> Processor GPIB bus data lines; used to carry message and data bytes in a bit-parallel byte-serial form controlled by the three handshake signals. These lines are TTL compatible.
DIO* DIO8*	22, 19, 18, 17, 16, 15, 13, 12	I/O	<b>Data Input/Output:</b> IEEE GPIB bus data lines. They are TTL compatible Schmitt-triggers when used for input and can sink 48 mA when used for output. See ATN and EOI description for output mode.

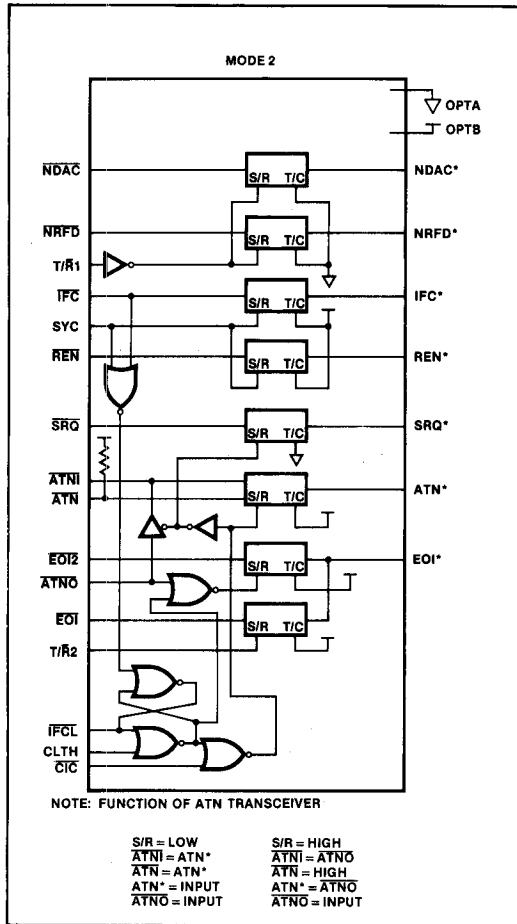

Figure 7. Talker/Listener/Controller Control Configuration

Table 5. Mode 2 Pin Description

Symbol	Pin No.	Type	Name and Function
$\overline{T/R1}$	1	I	<b>Transmit Receive 1:</b> Direction control for NDAC and NRFD. If $\overline{T/R1}$ is high, then NDAC and NRFD are receiving. Input is TTL compatible.
$\overline{NDAC}$	10	I/O	<b>Not Data Accepted:</b> Processor GPIB bus handshake control line; used to indicate the condition of acceptance of data by device(s). This pin is TTL compatible.
NDAC*	18	I/O	<b>Not Data Accepted:</b> IEEE GPIB bus handshake control line. It is a TTL compatible Schmitt-trigger when used for input and an open-collector driver with a 48 mA current sink capability when used for output.
NRFD	9	I/O	<b>Not Ready For Data:</b> Processor GPIB bus handshake control line; used to indicate the condition of readiness of device(s) to accept data. This pin is TTL compatible.
NRFD*	17	I/O	<b>Not Ready For Data:</b> IEEE GPIB bus handshake control line. It is a TTL compatible Schmitt-trigger when used for input and an open-collector driver with a 48 mA current sink capability when used for output.
SYC	22	I	<b>System Controller:</b> Used to monitor the system controller switch and control the direction for IFC and REN. This pin is a TTL compatible input.
$\overline{REN}$	6	I/O	<b>Remote Enable:</b> Processor GPIB control line; used by the active controller (in conjunction with other messages) to select between two alternate sources of device programming data (remote or local control). This pin is TTL compatible.
REN*	13	I/O	<b>Remote Enable:</b> IEEE GPIB bus control line. When used as an input, this is a TTL compatible Schmitt-trigger. When an output, it is a three-state driver with a 48 mA current sinking capability.
$\overline{IFC}$	5	I/O	<b>Interface Clear:</b> Processor GPIB bus control line; used by the active controller to place the interface system into a known quiescent state. This pin is TTL compatible.
IFC*	12	I/O	<b>Interface Clear:</b> IEEE GPIB control line. This is a TTL compatible Schmitt-trigger when used for input and a three-state driver capable of sinking 48 mA current when used for output.
$\overline{CIC}$	24	I	<b>Controller In Charge:</b> Used to control the direction of the SRQ and to indicate that the 8292 is in charge of the bus. $\overline{CIC}$ is a TTL compatible input.
Symbol	Pin No.	Type	Name and Function
CLTH	21	I	<b>Clear Latch:</b> Used to clear the IFC Received latch after it has been recognized by the 8292. Normally low (except after a hardware reset), it will be pulsed low when IFC Received is recognized by the 8292. This input is TTL compatible.
$\overline{IFCL}$	25	O	<b>IFC Received Latch:</b> The 8292 monitors the IFC line when it is not the active controller through this pin.
$\overline{SRQ}$	8	I/O	<b>Service Request:</b> Processor GPIB control line; indicates the need for attention and requests the active controller to interrupt the current sequence of events on the GPIB bus. This pin is TTL compatible.
SRQ*	16	I/O	<b>Service Request:</b> IEEE GPIB bus control line. When used as an input, this pin is a TTL compatible Schmitt-trigger. When used as an output, it is an open-collector driver with a 48 mA current sinking capability.
$\overline{T/R2}$	2	I	<b>Transmit Receive 2:</b> Controls the direction for EOI. This input is TTL compatible.
$\overline{ATNO}$	23	I	<b>Attention Out:</b> Processor GPIB bus control line; used by the 8292 for ATN control of the IEEE bus during "take control synchronously" operations. A low on this input causes ATN to be asserted if $\overline{CIC}$ indicates that this 8292 is in charge. $\overline{ATNO}$ is a TTL compatible input.
$\overline{ATNI}$	11	O	<b>Attention In:</b> Processor GPIB bus control line; used by the 8292 to monitor the ATN line. This output is TTL compatible.
$\overline{ATN}$	4	O	<b>Attention:</b> Processor GPIB bus control line; used by the 8292 to monitor the ATN line. This output is TTL compatible.
ATN*	19	I/O	<b>Attention:</b> IEEE GPIB bus control line; used by a controller to specify how data on the DIO signal lines are to be interpreted and which devices must respond to data. When used as an output, this pin is a three-state driver capable of sinking 48 mA current. As an input, it is a TTL compatible Schmitt-trigger.
$\overline{EOI2}$	7	I/O	<b>End Or Identify 2:</b> Processor GPIB bus control line; used in conjunction with ATN by the active controller (the 8292) to execute a polling sequence. This pin is TTL compatible.
$\overline{EOI}$	3	I/O	<b>End Or Identify:</b> Processor GPIB bus control line; used by a talker to indicate the end of a multiple byte transfer sequence. This pin is TTL compatible.

**Table 5. Mode 2 Pin Description (Continued)**

Symbol	Pin No.	Type	Name and Function
EOI*	15	I/O	<b>End Or Identify:</b> IEEE GPIB bus control line; used by a talker to indicate the end of a multiple byte transfer sequence or, by a controller in conjunction with ATN, to execute a polling sequence. When an output, this pin can sink 48 mA current. When an input, it is a TTL compatible Schmitt-trigger.

**Table 6. Mode 3 Pin Description**

Symbol	Pin No.	Type	Name and Function
T/R1	1	I	<b>Transmit Receive 1:</b> Controls the direction for DAV and the DIO lines. If T/R1 is high, then all these lines are sending information to the IEEE GPIB lines. This input is TTL compatible.
EOI ATN	3 4	I I	<b>End Of Sequence and Attention:</b> Processor GPIB control lines. These two control lines are ANDed together to determine whether all the transceivers in the 8293 are push-pull or open-collector. When both signals are low (true), then the controller is performing a parallel poll and the transceivers are all open-collector. These inputs are TTL compatible.
ATN0	11	I	<b>Attention Out:</b> Processor GPIB control line; used by the 8292 during "take control synchronously" operations. This pin is TTL compatible.
IFCL	2	I	<b>Interface Clean Latched:</b> Used to make DAV received after the system controller asserts IFC. This input is TTL compatible.
DAV	24	I/O	<b>Data Valid:</b> Processor GPIB handshake control line; used to indicate the condition (availability and validity) of information on the DIO signals. This pin is TTL compatible.
DAV*	21	I/O	<b>Data Valid:</b> IEEE GPIB handshake control line. When an input, this pin is a TTL compatible Schmitt-trigger. When DAV* is an output, it can sink 48 mA.
DIO1- DIO8	25, 23, 10, 9, 8, 7, 6, 5	I/O	<b>Data Input/Output:</b> Processor GPIB bus data lines; used to carry message and data bytes in a bit-parallel byte-serial from controlled by the three handshake signals. These lines are TTL compatible.
DIO1* DIO8*	22, 19, 18, 17, 16, 15, 13, 12	I/O	<b>Data Input/Output:</b> IEEE GPIB bus data lines. They are TTL compatible Schmitt-triggers when used for input and can sink 48 mA when used for output.

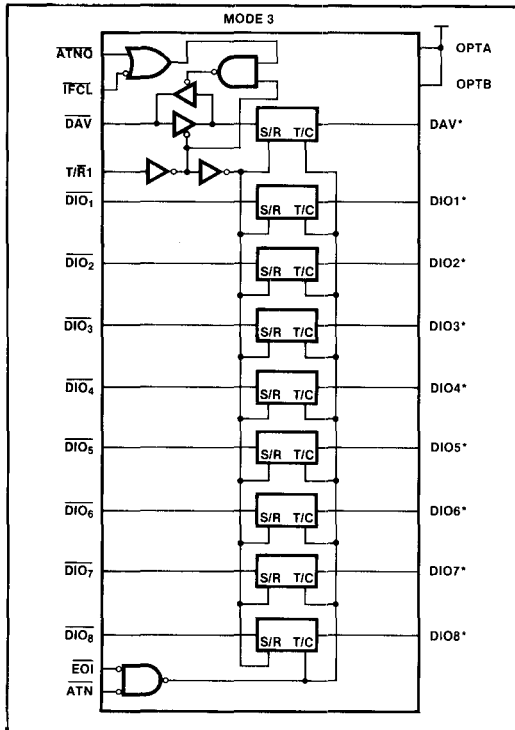

**Figure 8. Talker/Listener/Controller Data Configuration**

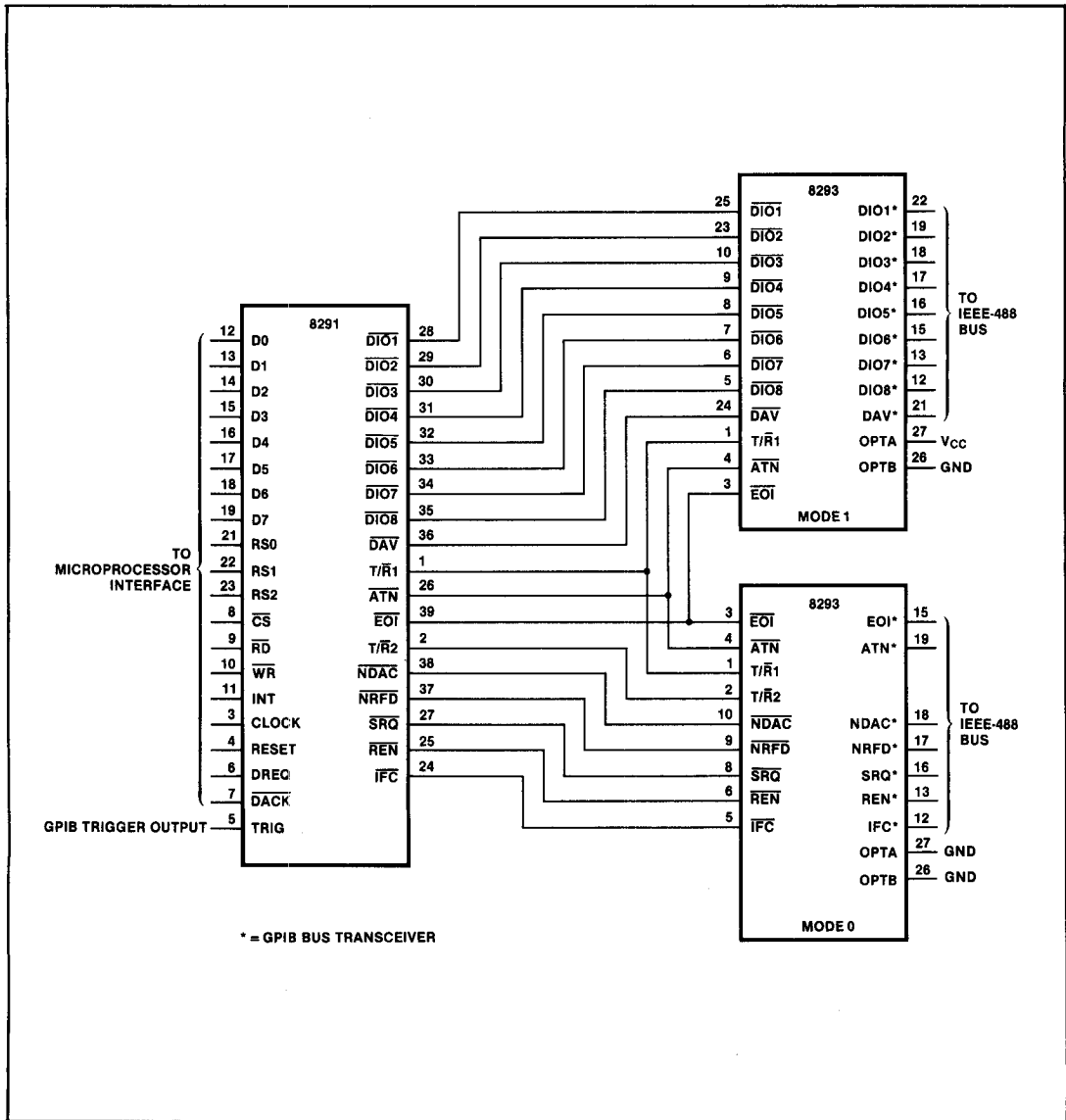

Figure 9. 8291 and 8293 System Configuration



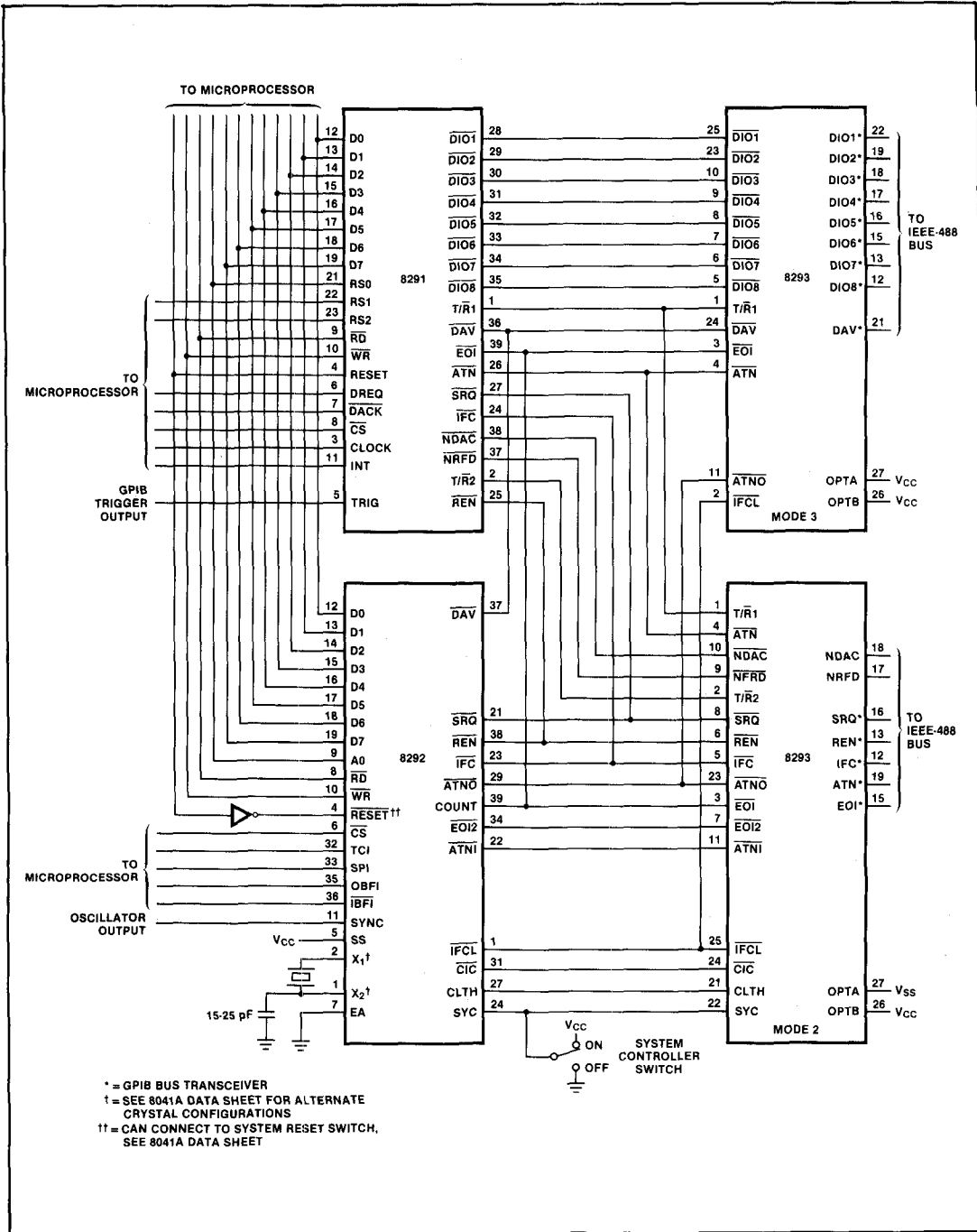

Figure 10. 8291, 8292, and 8293 System Configuration

**ABSOLUTE MAXIMUM RATINGS\***

Ambient Temperature Under Bias . . . . . 0°C to 70°C  
 Storage Temperature . . . . . - 65°C to + 150°C  
 Voltage on any Pin with  
     Respect to Ground . . . . . - 1.0V to + 7V  
 Power Dissipation . . . . . 1 Watt

*\*NOTICE: Stresses above those listed under "Absolute Maximum Ratings" may cause permanent damage to the device. This is a stress rating only and functional operation of the device at these or any other conditions above those indicated in the operational sections of this specification is not implied. Exposure to absolute maximum rating conditions for extended periods may affect device reliability.*

**D.C. CHARACTERISTICS** ( $T_A = 0^\circ\text{C}$  to  $70^\circ\text{C}$ ,  $V_{CC} = 5.0\text{V} \pm 10\%$ ,  $\text{GND} = 0\text{V}$ )

Symbol	Parameter	Limits			Unit	Test Conditions
		Min.	Typ.	Max.		
$V_{IL1}$	Input Low Voltage (GPIB Bus Pins)			0.8	V	
$V_{IL2}$	Input Low Voltage (Option Pins)	-0.1		0.1	V	
$V_{IL3}$	Input Low Voltage (All Others)			0.8	V	
$V_{IH1}$	Input High Voltage (GPIB Bus Pins)	2.0			V	
$V_{IH2}$	Input High Voltage (Option Pins)	4.5		5.5	V	
$V_{IH3}$	Input High Voltage (All Others)	2.0			V	
$V_{OL1}$	Output Low Voltage (GPIB Bus Pins)			0.5	V	$I_{OL} = 48\text{ mA}$
$V_{OL2}$	Output Low Voltage (All Others)			0.5	V	$I_{OL} = 16\text{ mA}$
$V_{OH1}$	Output High Voltage (GPIB Bus Pins)	2.4			V	$I_{OH} = -5.2\text{ mA}$
$V_{OH2}$	Output High Voltage (All Others)	2.4			V	$I_{OH} = -800\ \mu\text{A}$
$V_{IH4}$	Receiver Input Hysteresis	400	600		mV	
$V_{IT}$	Receiver Input Threshold	High to Low	0.8	1.0	V	
		Low to High		1.6		
$I_{LI1}$	Low Input Load Current (GPIB Bus Pins)	-3.2		0.0	mA	$V_{IL} = 0.8\text{V}$
$I_{IL}$	Input Leakage Current (All Others)			10	$\mu\text{A}$	$0.4\text{V} \leq V_{IN} \leq V_{CC}$
$I_{PD}$	Bus Power Down Leakage Current			40	$\mu\text{A}$	$0\text{V} \leq V_{BUS} \leq 2.7\text{V}$
$I_{CC}$	Power Supply Current		110	175	mA	

**CAPACITANCE**

Symbol	Parameter	Min.	Typ.	Max.	Unit	Test Conditions
$C_{IO1}$	I/O Capacitance (GPIB Side)		50	60	pF	$V_{IN} = V_{CC}$
$C_{IO2}$	I/O Capacitance (System Side)		40	50	pF	$V_{OUT} = V_{CC}$
$C_{ITR}$	Input Capacitance ( $T/\bar{R}1$ , $T/\bar{R}2$ )		10	20	pF	$V_{IN} = V_{CC}$

**A.C. CHARACTERISTICS** ( $T_A = 0^\circ\text{C}$  to  $70^\circ\text{C}$ ,  $V_{CC} = 5.0\text{V} \pm 10\%$ ,  $\text{GND} = 0\text{V}$ )

Symbol	Parameter	Typ.*	Max.	Units
$t_{p1}$	Transmitter Propagation Delay (All Lines)	20	35	ns
$t_{p1}$	Receiver Propagation Delay (EOI, ATN and Handshake Lines)	30	50	ns
$t_{p3}$	Receiver Propagation Delay (All Other Lines)	40	60	ns
$t_{PHZ1}$	Transmitter Disable Delay (High to 3-State)	20	35	ns
$t_{PZH1}$	Transmitter Enable Delay (3-state to High)	20	35	ns
$t_{PLZ1}$	Transmitter Disable Delay (Low to 3-State)	25	40	ns
$t_{PZL1}$	Transmitter Enable Delay (3-State to Low)	15	30	ns
$t_{PHZ2}$	Receiver Disable Delay (High to 3-State)	25	40	ns
$t_{PZH2}$	Receiver Enable Delay (3-State to High)	20	35	ns
$t_{PLZ2}$	Receiver Disable Delay (Low to 3-State)	25	40	ns
$t_{PZL2}$	Receiver Enable Delay (3-State to Low)	20	35	ns
$t_{MS}$	Mode Switch Delay		10	$\mu\text{s}$

\*Typical @  $T_A = 25^\circ\text{C}$ .

TYPICAL OUTPUT LOADING CIRCUITS

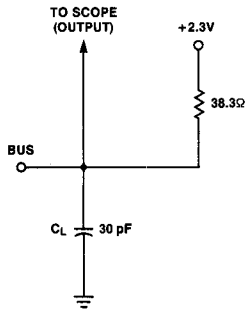

C<sub>L</sub> INCLUDES JIG AND PROBE CAPACITANCE

Data Input to Bus Output (Driver)

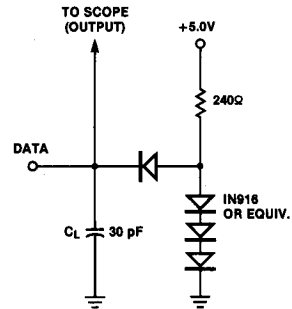

C<sub>L</sub> INCLUDES JIG AND PROBE CAPACITANCE

Bus Input to Data Output (Receiver)

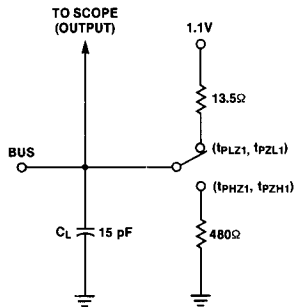

C<sub>L</sub> INCLUDES JIG AND PROBE CAPACITANCE

Send/Receive Input to Bus Output (Driver)

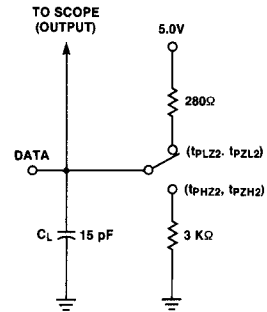

C<sub>L</sub> INCLUDES JIG AND PROBE CAPACITANCE

Send/Receive Input to Data Output (Receiver)

WAVEFORMS

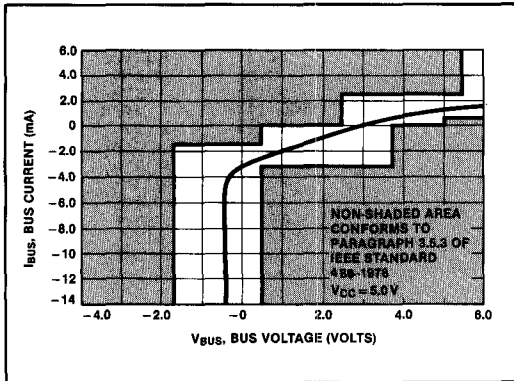
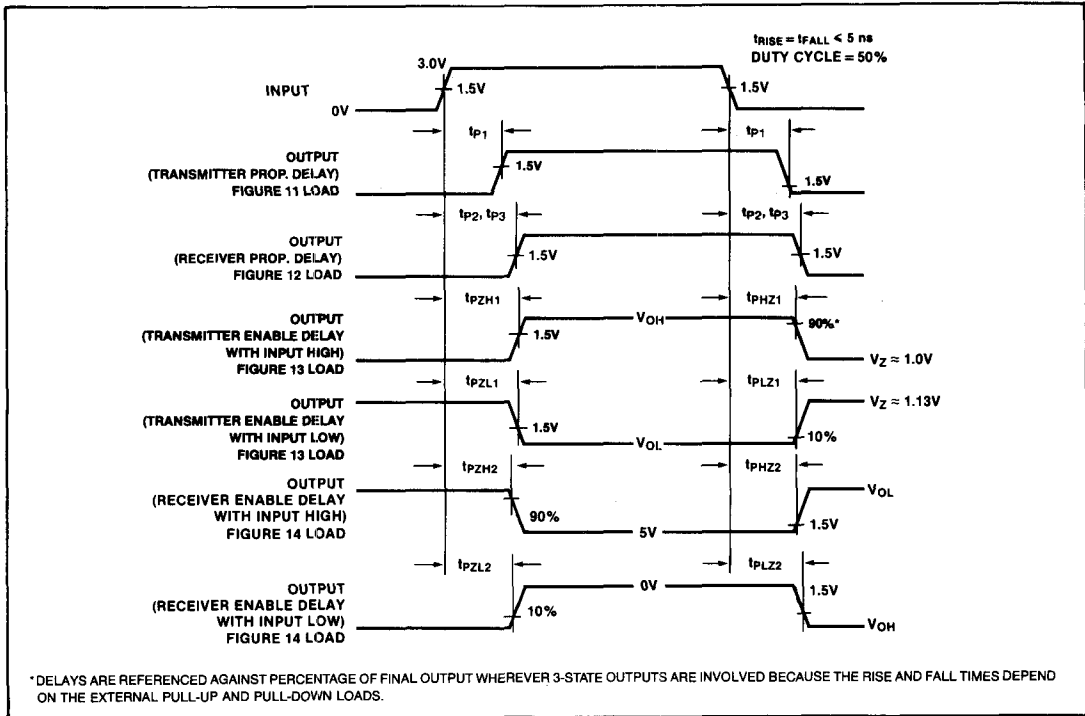

Typical Bus Load Line

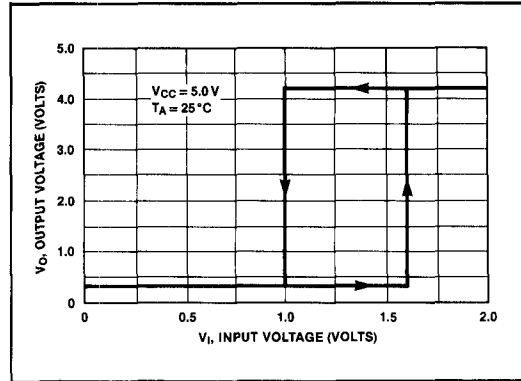

Typical Receiver Hysteresis Characteristics